



Veivuke ni Veivakavaletaki

Na veika me caka e na kena tara vou
tale vakavinaka e dua na vale



Nai walewale ni kena tara vou tale
edua na vale me vorata na vei leqa
tubu koso



 **Shelter Cluster Fiji**
ShelterCluster.org
Coordinating Humanitarian Shelter





Veivuke ni Veivakavaletaki

Na veika me caka e na kena tara vou tale vakavinaka e dua na vale

LEWE NI IVOLA

Na Ivakamacala

1. Tara nomu vale e na vanua taqomaki	5
2. Tara vale e na yavu kaukauwa	7
3. Vesuka sobu mai cake I ra ka vakayagataka na isema kaukauwa	
- Sega ni rauta na ivako walega	9
4. Vakadre mai na cava	11
5. Na vale vinaka e gadreva e dua na doka vinaka	13
6. Me kua ni biu tu mai e dua	15
7. Mo vakarau tu	17
<i>Cakava oqo me na kaukauwa cake na nomu vale</i> Yaloyalo	18
<i>Na veika rawarawa me caka e na dua na doka ni vale</i> Yaloyalo	20
<i>Dusidusi ni taravale vakaitaukei</i> Yaloyalo	22
<i>Vakayagataka vaka maqosa na ilavo lailai ka me yaga vakadede</i> Yaloyalo	24
<i>E na so na gauna e sega ni rauta nai vako wale ga</i> Yaloyalo	26
Na kena vakavinakataka cake na vale o tiko kina oqo	28
So tale nai vasala ena kena tara vakavinaka cake e dua na vale	31
Vei tukutuku tale eso	32

© Shelter Cluster Fiji, 2016

Oqo e dua nai vola vakarautaki, ka rawa ni veikereitaki na kena vei gacagaca eso kina veiqaravi tale eso. Ia me qai vakalesui tuga main a vanua e kau mai kina.

Na kena vakamuri vakavinaka nai walewale ni tara vale ena I vola vakarautaki oqo e sa na vakatautaki sara ga vei keda yadua, kabani, se I soqosoqo.

Ena taba ni pepa 32 e cake, e tabaki toka kina na yacadra na vei soqosoqo ka ra a vakaitavi ena kena vakarautaki na I vola vakarautaki oqo. Kevaka ko vinakata mo tabaka tale na I lavelave oqo, sa rawa mo na tabaka na nomu I vakatakilakila ena drauni pepa 32 e ra, ka me kakua ga ena daku ni vola oqo.

Cover photo: Building Back Safer training run by Shelter Cluster Fiji and Habitat for Humanity in May 2016 (source Shelter Cluster Fiji)





Shelter Cluster Fiji
ShelterCluster.org
Coordinating Humanitarian Shelter



Na vale oqo e kunei ni a sega ni vakacacani ena cagilaba ko TC Winston, ia era a vakacacani na vo ni veileva era tiko tikiva. Ko na rawa ni raica na kena beleti taki na veileva eso ka vaka kina na lalaga kei na doka ena kena vakoti na i sema kaukamea kina kau (Source Habitat for Humanity)



Na vale oqo e a tara ni sa oti ko TC Winston, ka a vakayagataki kina na veileva ni taravale oqo. (Source Fiji Red Cross Society/IFRC).



Ni mai vakanadaku na cagilaba ko Winston e kunei ni 31,200 na vale era a vakacacani, ka mani sagai mai vua na matanitu ko Viti me sa qaravi e dua na cakacaka ni veileva vakacokotaki ka vakatokai na Veivuke ni Veivakavaletaki ka tuvani e dua na kena i tuvatuva me rawa ni ra volia tale na nodra I yaya ni vale ko ira era a vakarusai vakadua se vakacacani vakavo na nodra vale.

Ena vica na vakadidike ni veileva vakacokotaki oqo, e kunei kina na kena lailai na i vurevure ni veika e rawa ni vakayagataki kei na kena muri tikoga nai walewale ni tara vale makawa ka laurai ni na vaka vu leqa ena vanua ko Viti ena gauna ni veileva tubu koso eso.

Na I vola vakarautaki oqo e vakarautaki me vukei keda ena kena vaqacacotaki na noda kila ka ena I walewale kei na I vakarau ni noda tara vale me rawa kina ni da vorata na veileva tubu koso eso.

Mr Kolinio Bola

Director ni Veivakavaletaki, Shelter Cluster Fiji Lead



Na veika me caka e na kena tara vou e dua na vale tale vakavinaka e dua na vale



Shelter Cluster Fiji
ShelterCluster.org
Coordinating Humanitarian Shelter

Kakua ni tara vale voleka kina bati ni baba se kina yasana e dau sisi rawarawa mai kina na vatu se qele.

Tea e so na vunikau me i vakaruru ni cagi.

1. Raica vinaka na vanua me tara kina na nomu vale

- ✓ Tara na nomu vale ena dua na vanua e vakarurugi na kena I tuvaki me rawa ni maroro iko mai na leqa tubu koso e so.
- ✓ E so na vanua me na dau qarauni ena noda via tara vale, ulunivanua, batinimatasawa, vanua bucabuca e rawa ni waluvu, gusu ni uciwai.
- ✓ Vakadurubalavu taka na nomu vale ena vanua e dau luvu wasoma.

Nai walewale ni kena tuvalaki e dua na veivakavaletaki

Na veivolekati ni vale ena vakavuna na kena tasogo na toso ni cagi.

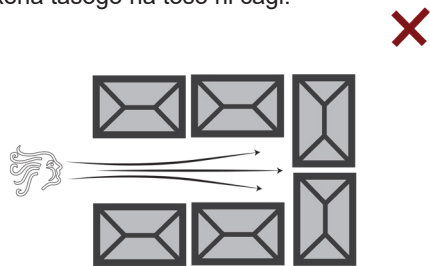

Na veiyawaki ni vale ena vaka vuna na galala ni toso ni cagi.

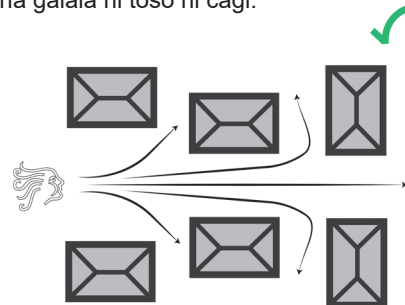

Musuka laivi na vei vunikau lelevu ena vanua ko via tara vale kina, ia ke sega mo vaka yawaka mai na nomu vale me lailai kina na vaka caca, ke bale na kau.

Ko na vaka lailai taka na vakacacani ni nomu vale kevaka ko tara vale tani mai na vanua e rawa ni yaco kina na leqa.





Na veika me caka e na kena tara vou e na kena tara vou e dua na vale e dua na vale



Shelter Cluster Fiji
ShelterCluster.org
Coordinating Humanitarian Shelter

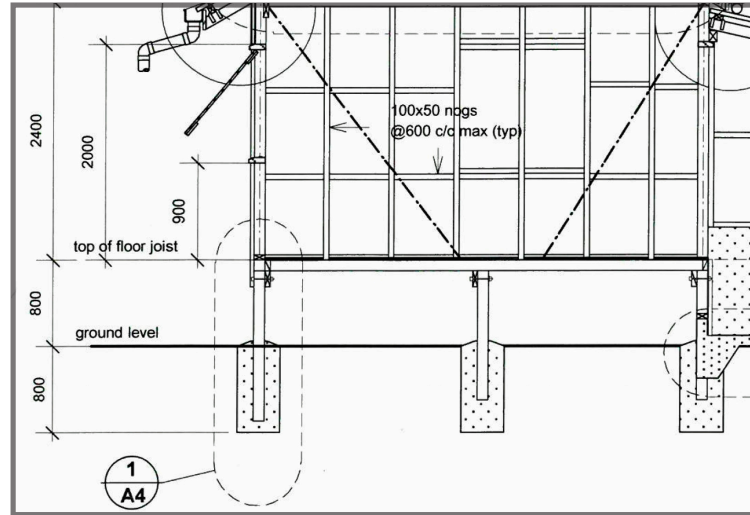

Core shelter design with strong foundation. (Source Fiji Red Cross Society/IFRC).

2. Tara vale ena yavu e kaukauwa

- ✓ Kelia na qara ni duru me 0.75m na kena titobu, vaka qara taka na baba ni duru me curumaki kina na kaukamea ni bera ni biu sobu ena loma ni qara me simede taki.
- ✓ Raica me dau maka ka totoka na yavu kei na vanua me dabe kina na nomu vale.

Na cava au rawa ni vagataka me rawa ni yavudei ni tnoqu vale

Duru ka duri ena dela ni qele

Duru ka bulu ena loma ni qele

Na kau e vakoti ena baba ni duru

Duru kaukauwa ka vaka waini mate taki e bulu me tarova na vuca

Na duru kaukauwa ka bulu ena yavu ka simede taki

Na kaukamea ka bulu ena loma ni yavu e simede taki

Na duru e beleti taki ena beleti kaukamea me tarova na vuca

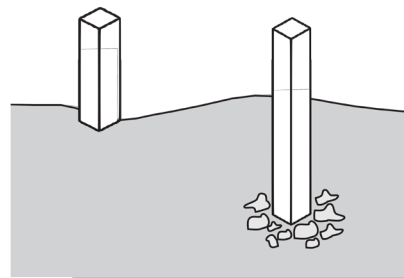

E Malumalumu ❌

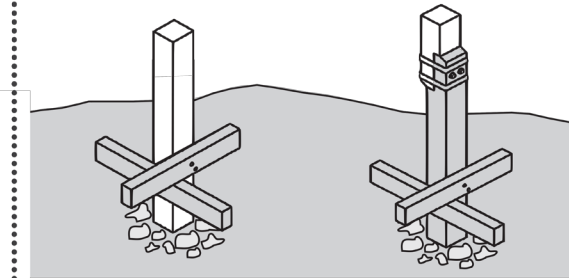

E Kaukauwa ✓

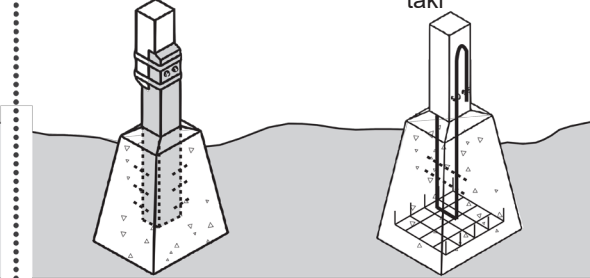

Kaukauwa Cake ✓

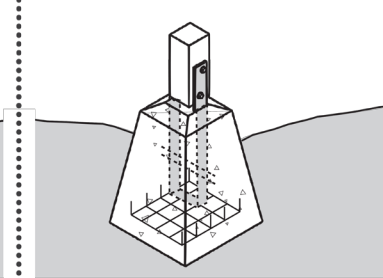

Kaukauwa Cake Sara ✓✓





Na veika me caka tale vakavinaka e na kena tara vou e dua na vale



Shelter Cluster Fiji
ShelterCluster.org
Coordinating Humanitarian Shelter



Me vakabalavutaki na beleti me rawa ni vakoti kina e va nai vako ena yasana ruarua. Me vakadreti vakababa vakavinaka na beleti me rawa ni mokota na yasa ruarua.

3. Me vesuki vakavinaka mai na botona kina dokana ka mevakayagataki nai vei sema kaukauwa . – Sa sega ni rauta walega na I vako

- ✓ Qarauna me semati vakaukauwa na vei semakece mai na kava kina kena I toka, ka vakatalega kina mai na doka kina lalaga kei na lalaga kina yavu.
- ✓ Vakalevutaka na I vako ena veisema kece ni nomu vale.
- ✓ Tara vakaukauwa na veisema kece ni vale me dredre kina ni biligi se yavalati. Sa sega ni veiraurau na kena vakoti na veisema eso e na I vako keina kaukauwa ni cagi ka rawa ni ko vakayagatakatale eso na I yaya mevaka na beleti kava, dali kei na wa kaukamea me vakadreti kina vakavinaka na veisema eso.

NA CAVA SO NA KA AU RAWA NI VAKAYAGATAKA MEU VAKADREETAKA

Na dali nailoni se na wan i siwa

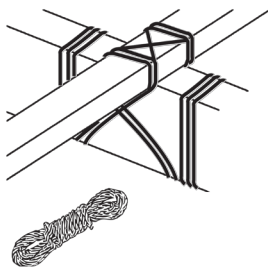

Na wa veiqali kaukamea

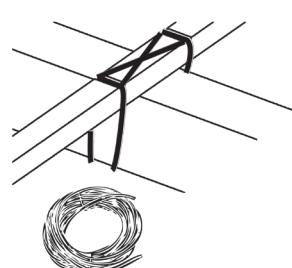

Kaukauwa ✓

Na musumusu ni kau

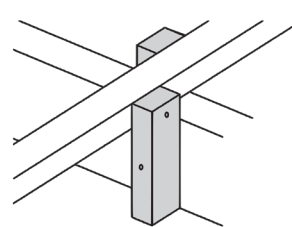

KINA NA NOQU VALE?

Na beleti kava

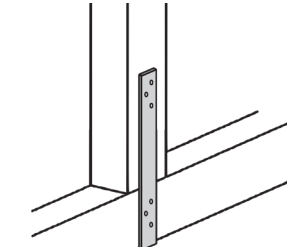

E Kaukauwa Cake Sara ✓✓

NA I VAKARO NI CAVA KAUKAUWA?

Vesuka vakavinaka ni sa tau mai na I vakaro ni cagi kaukauwa

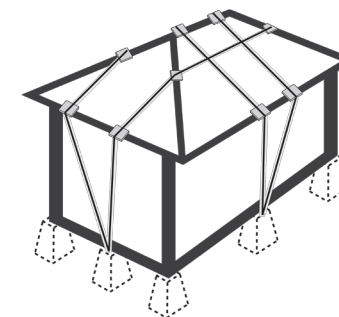



**Na veika me caka e na kena tara vou
tale vakavinaka e dua na vale**



Shelter Cluster Fiji
ShelterCluster.org
Coordinating Humanitarian Shelter

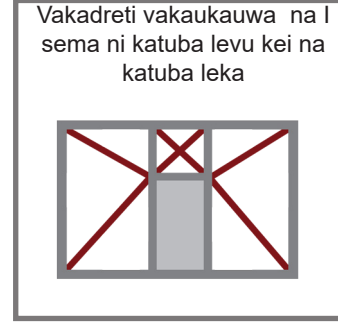
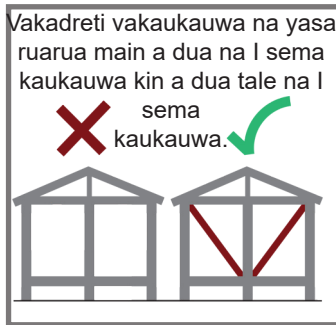
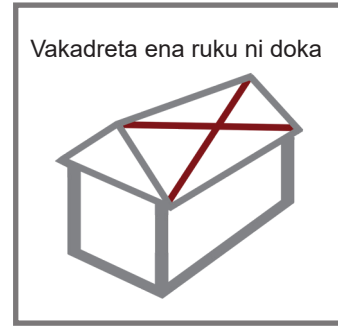

4. Na l vakadei vinaka ena gauina ni cagilaba

- ✓ Na beleti kaukauwa ena maroroya na nomu vale me kua ni vakacacani ena gauna ni cagilaba
- ✓ Me beleti taki na veisema kaukauwa ni vale
- ✓ Me dau vakoti vakababa na beleti ki na lalaga vata kei na doka

NA CAVA SO NA KA AU RAWA NI VAKAYAGATAKA MEU VAKADRETA KINA NA NOQU VALE

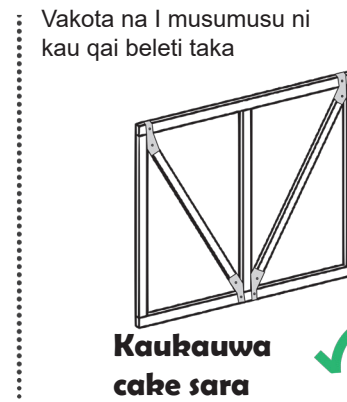
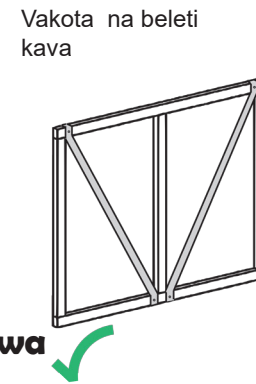
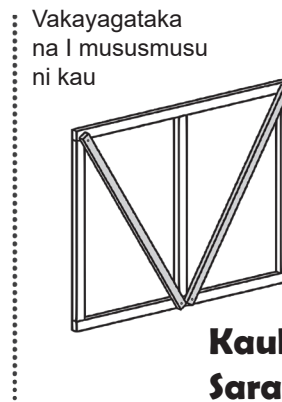
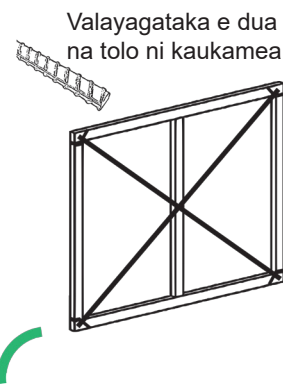
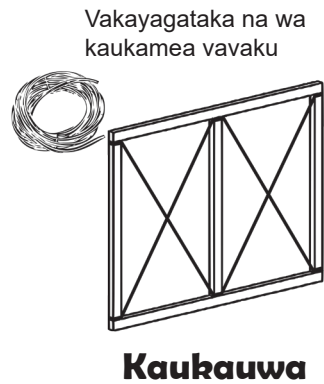

10

11





Na veika me caka e na kena tara vou e dua na vale tale vakavinaka e dua na vale



Shelter Cluster Fiji
ShelterCluster.org
Coordinating Humanitarian Shelter

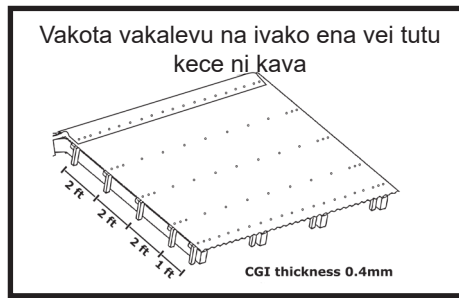
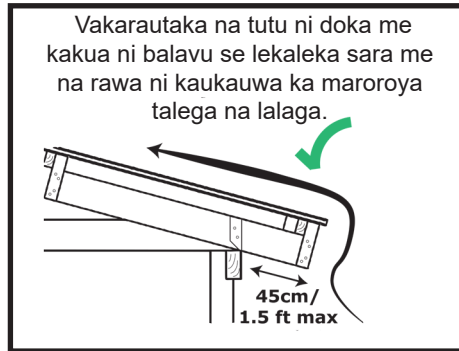
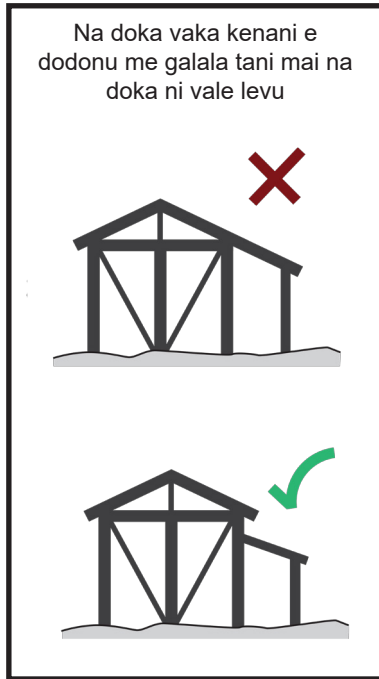

5. Me vinaka na vale ena gadrevi kina e dua na doka vinaka

- ✓ Tara na nomu doka ni vale ena dua na kena I bulibuli e rakorako ka matau qai vakota vakavinaka me rawa ni maroroya mai na cagilaba. Na vale doka va ka davo na kena doka ena 30 kina 40 na dikiri e kunei ni dau veiraurau vinaka kei na kaukauwa ni cagi
- ✓ Ena kaukauwa ka dei vinaka na kava ena doka ni vale ke-vaka ko vakayagataka kina na I vako sukuru[screws nails] me qai vakatalega kina e na vei tutu ni kava
- ✓ Na doka ni varada se poji e dodonu me kua ni semati kina doka ni vale levu
- ✓ Na tutu ni doka ena kaukauwa kevaka e rauta ni 45 na senitimita na kena balavu

NA I BULIBULI NI DOKA CAVA MEU VAKAYAGATAKA

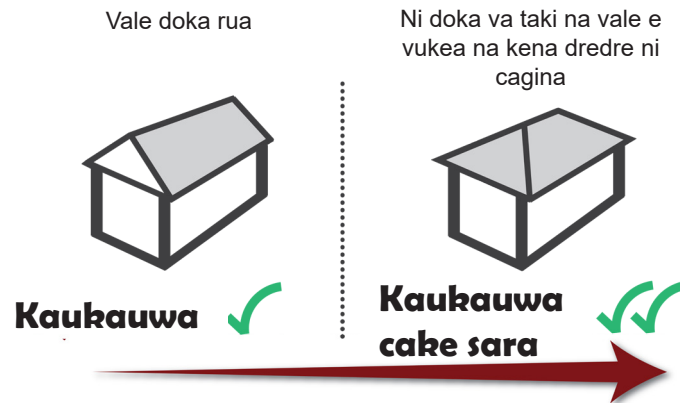



Na veika me caka e na kena tara vou e dua na vale tale vakavinaka

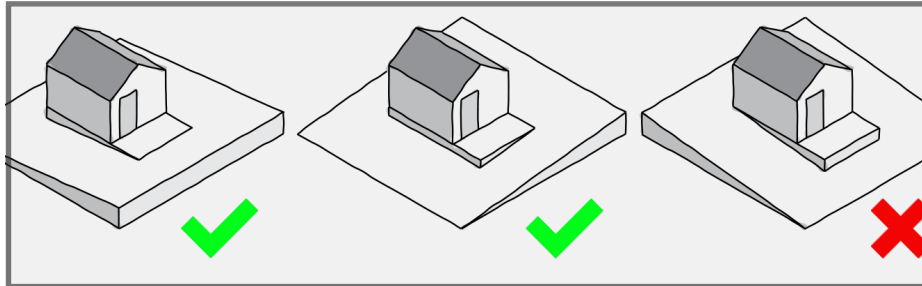

Me qara na vale kina vanua e cere, ke sega me qara kina na yasa ni vale

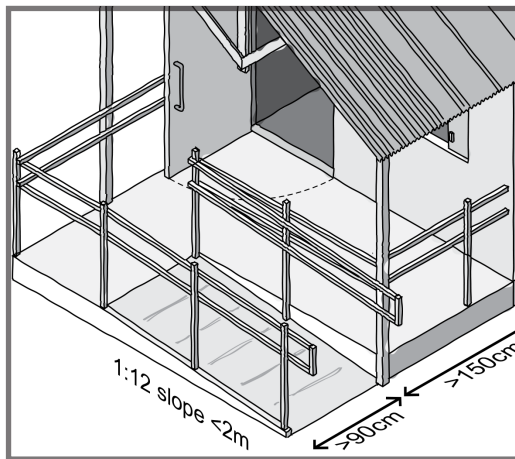

Vakota na I tatakube ena tutu ni kawakawa se kabakaba me rawa ni vakarawarawataka na veitosa yaki vei ira na malumalumu kei ira na sega ni rai vinaka

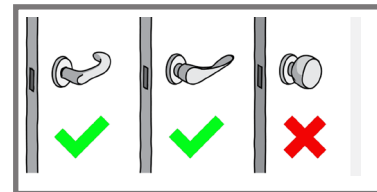

Vakayagataka na katuba kei na katuba leka e mamada ka rawarawa na kena dolavi na kena I doladola me rawa ni ganiti ira tale ga e ra vakaleqai tu na I tuvaki ni yagodra.

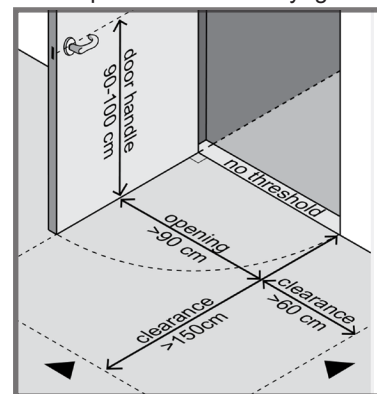

**All drawings are from the Under One Roof guideline on disability inclusive shelter and settlements in emergencies*

6. Me kakua ni dua me na guilecavi

- ✓ Na I vola vakarautaki oqo e nanumi me ra kauwaitaki talega kina na nodra bula o ira era vakaleqai tu na I tuvaki ni yagodra. Ena lailai n aka eda vakayagataka kevaka eda biuta e dua nai taratara ni vale ka sa tiko kina na veika e baleti ira mai na noda qai saga e muri na veiveisau.
- ✓ Tara na nomu vale me vakanadakuya na baba ka me kakua ga ni qara kina
- ✓ Na I kawakawa ka vakarautaki me baleti ira era vakaleqai tu na I tuvaki ni yagodra e dodonu me 900na senitimita na kena raba na ka me davo toka ena 1:10 kina 1:2 na dikiri ka me kua talega ni sisisi na kena buturara
- ✓ Me dau biu talega na I tatakube ena yasa ni kawakawa, varada, vale ni vakacegu vata kei na vale ni sili
- ✓ Me kakua ni lailai mai na 90 na senitimita na raba ni katuba kece, ka me rauta ni 1.00 na mita na cere ni kena idoladola mai na buturara ni vale
- ✓ Na katuba kece ena vale ni vakacegu kei na vale ni sili e dodonu me dolavi mai tuba



**Na veika me caka e na kena tara vou
tale vakavinaka e dua na vale**



Shelter Cluster Fiji
ShelterCluster.org
Coordinating Humanitarian Shelter

Biuta tale eso na beleti me I vakadre Vakarautaka e dua na rumu ena loma ni vale me I drodro. Biuta na I tatarovi ni cagi ena vei katuba kece. Tamusuka laivi na vei vunika lelevu ena yasa ni nomu vale. Tei vaka eso na vunika lalai ena yasa ni nomu vale me I vakaruru ni cagi. Au na vakarautaka beka vakacava na noqu vale, na noqu bula ke I na noqu I tikotiko ena gauna ni leqa tubu koso.



7. Mo vakavakarau

- ✓ E bibi meda dau vakavakarau ni sa I koya ga oqo na sala eda na vakalailaitaka kina na vakacaca ena gauna ni vei leqa tubu koso eso.
- ✓ Sa bibi na noda vakavakarau ena kena tovolei me botani se vakoti vakavinaka na vei vanua eso ka na rawa ni curuma yani na cagi
- ✓ Kevaka sa soli na I vakaro ni leqa tubu koso, e dodonu me vesuki ka vakadretaki vakavinaka na nomu vale, biu ena I vatavata e cake na I yaya ena gauna ni waluvu, ka maroroi vinaka na von i yaya me kakua ni cevuka se vakacacani

HOW CAN I PREPARE MY HOUSE, MYSELF AND MY COMMUNITY FOR A DISASTER?



NA I DRODRO



Tuvalaka e dua nai tuvatuva qai vakavakarau kina Lewa vakamatau na nomu toki kina I drodro se ko na tiko ga ena nomu vale
Me tiko e dua na gaunisala e rawarawa
Mo kila na vanua e tiko kina na i drodro
Na sala ni veitosoyaki cava mo na vakayagataka



SALA NI VEIVOSAKI SE VEITARATARA



Mo kila na i vakatakilakila ni sa vakasalataki yani na vei leqa tubu koso eso
Mo kila na veisala eso ko na rawa ni ciqoma kina na I tukutuku nib era ni ko na qai vakasalataki ira na wekamu se ko ira na nomu I tokani ena vanua mo ni lako kina

Mo kila se sala cava ko na rawa ni tarai ira kina na wekamu se ko ira na nomu I tokani ni oti e dua na leqa tubu koso

Mo kila na sala vata kei ira me tukuni vei ira na I tukutuku

Mo kila na vanua e soli kina na kedra I tukutuku ko ira era dau yali



NA KATO NI YAYA VAKARAU



Vakarautaka tiko e dua na kato ka na dreedre ni suasua nib era ni yaco e dua na leqa tubu koso:
Na kato vakarau oqo e dodonu me mamada g aka rawarawa na kena veikauyaki ka dodonu me tiko ena lomana na veika oqo.

- Eso na isulu kei na vava
- Na batiri ni raitio se cina
- Na icina vata kei na masese
- Na vei kakana eso ka rawarawa na kena vakarautaki
- Na vei yaya ni vakasaqari kakana eso
- Na vei yaya ni cakacaka ka dau rawaraw na kena vakayagataka
- Na vei yaya maroroi me vaka na ID card se I vola ni lavo
- Kakua ni guilecava me so talega na wai ni gunu



Na vei vakasala oqo ena vukea na kena na vakaukauwataki na nomu vale

Na veika me caka e na kena tara vou e dua na vale



Shelter Cluster Fiji
ShelterCluster.org
Coordinating Humanitarian Shelter

Ena vakalailaitaka na nomu vakayagataka na nomu I lavo kevaka ko tara vaka vuku ka matau na nomu vale

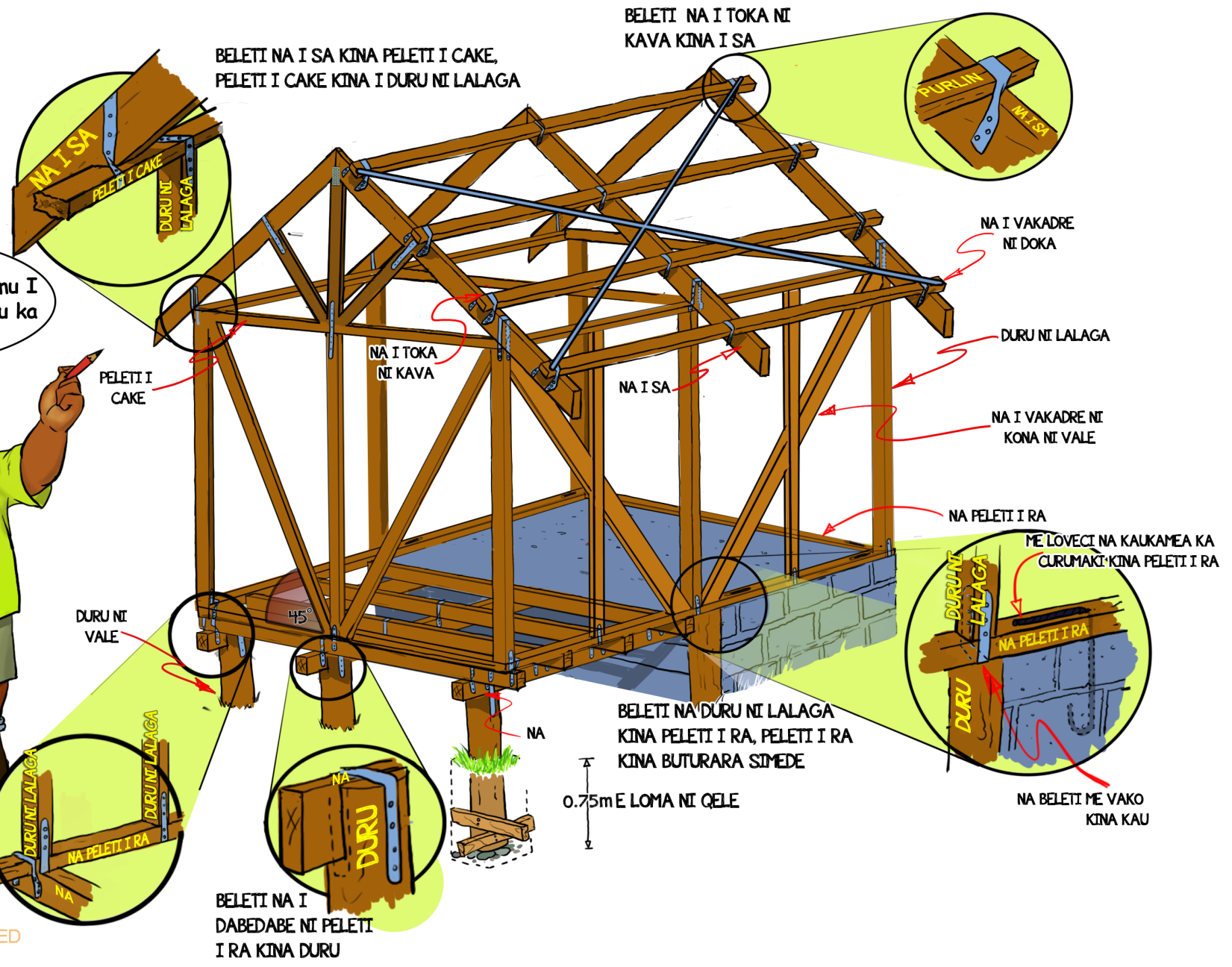

Original work and Supported by: ENTEC LIMITED

refer to the Home Builders Manual www.mit.gov.fj for more information





**Na veika me caka e na kena tara vou
tale vakavinaka e dua na vale**



Shelter Cluster Fiji
ShelterCluster.org
Coordinating Humanitarian Shelter

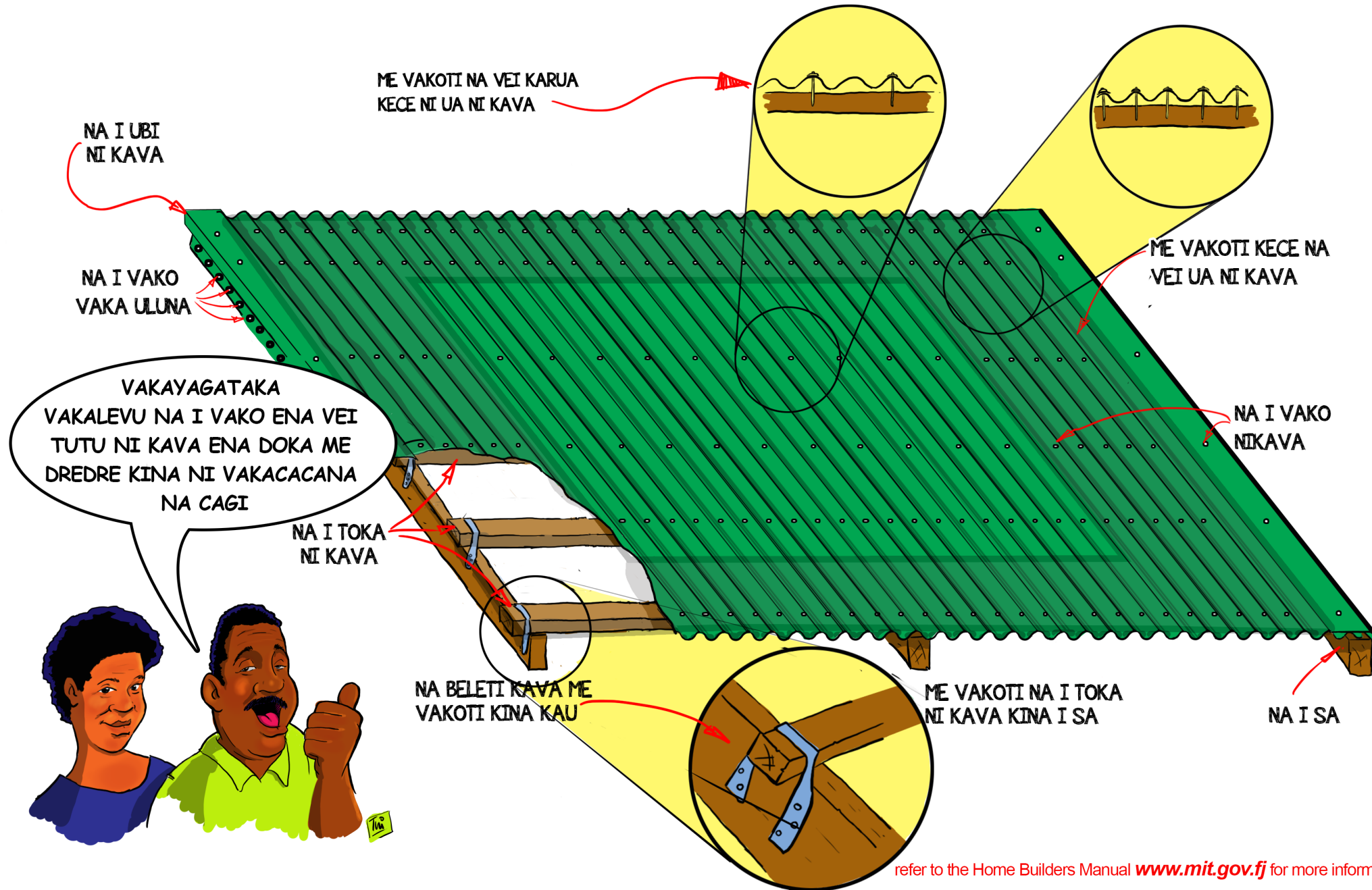

refer to the Home Builders Manual www.mit.gov.fj for more information



NA KENA SOTAVI NA CAGILABA KE NA VEILEQA TUBU KOSO ESO

FIJI

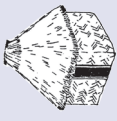
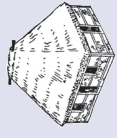
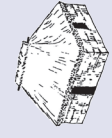
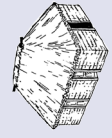

NAI TUKUTUKU TAUMADA ENA IVALEVALE NI KENA DAU TARA NA VALE

NA KENA I CAKACAKA TAUMADA

1 NA VALE DOKA VA



Traditional bure house with steeply pitched and hip roof

2 NA I TURU NI DOKA



Eaves are narrow in traditional bure houses in order to minimise roof tearing caused by winds

3 TARA ENA DELA NI DUA NA YAVU ME VUKEA NA DRODDRO NI WAI KA ME DREDRE TALEGA KINA NI LUVU



Traditional bure house built on a mound

ME T U D E I V A K A V I N A K A T A K A + + +

6 NA DURU KAUKAUWA LELEVA KA BULU VAKATI-TOBU ENA LOMA NI QARA



Interior of bure house with wooden structure

5 NA KUBU NI VALE



Rounded corners are found in either traditional and new built houses. This house is built with CI sheets

4 NA KENA VAKAVOLIVOLITI NA KORO ENA VEIKAU ESO ENA VUKEA KA VAKAMALUMUTAKA NA KAUKAUWA NI CAGI



This house's surroundings are full of trees which will mitigate wind effects

MEDA VULI MAI KINA



Shelter Cluster Fiji
ShelterCluster.org
Coordinating Humanitarian Shelter



ELAILAI SARA NA I LAVO KA BULA BALAVU NA NOMU VALE ME VEI VORATI KEI NA CAGILABA

Cakava na nomu vale me vei vorati kei na cagilaba ka sega ni gadrevi vaka levu kina nai lavo. Ia ena taura na gauna na kena vatavatairalago taki keina cakacaka. Oqo e so na ka e rawa ni ko tekivu kina mo vakaukauwataka na nomu vale ena ilavo lailai ka volia na iyaya oqo

1. Beleti kei na kenai vadreti:

1. Na beleti ka vako ena ivako vaka uluna
 2. Viviraki vakaukauwa ena waya
 3. Vesu vakaukauwa ena waniwasi
 4. Vesu ena wa magimagi
 5. Vakoti vata na kau
- Ena kaukauwa na isema ke vaka yagataki na I vako balavu, Vakayagataka naq I vako loveci na tolonga ka vakota me veilatai me vesuki rau vata vakaukauwa na kau ruarua
BALETA ENA VEI SEMA KECE E GADREVI KINA NA KA E LEVU CAKA MAI NA I VAKO

2. I sogo:

Cakava na isogo ni vei katubaleka. Oqo e rawa ni caka mai na kau se CGI. Tarova na cagi me tiko ga yani e tautuba ni vale.

3. Me vakadre vinaka na nomu doka, ialaga kei na yasa:

Raica me vei latai nai vakadre ni vale mai cake ka yaco ki ra ena nomu lalaga kei na doka ena kaukawa vinaka kina na vale ka dredre me kasura.

4. Veisau taka nai vako ni kava ena I vako sukuru ni cagilaba:

Oqo e rawa ni caka vaka tikina yani ke sa rawa ni voli. Tekivu wavoki ena yasa ni vale kani oqo na vanua edau tacavu ka laveti e liu. Sukuru taka taucoko na ua ni kava.

5. Cakava na nomu I kelekele simede ka me toka nai vesu rigi kaukamea se waya e dealana:

Na rigi ena vesu kina na dali me vakadre kina na vale. Raica nai kelekele me rabailevu na botonamai na uluna e cake.

6. Tara vaka vinaka na nomu vale lailai:

E levu sara na vale lailai erai matai ni vale me cagina laivi. E sau levu saran a kena ripea keina dredre ni bula ni sega na vale lailai

refer to the Home Builders Manual www.mit.gov.fj for more information

Na veika me caka e na kena tara vou tale vakavinaka e dua na vale

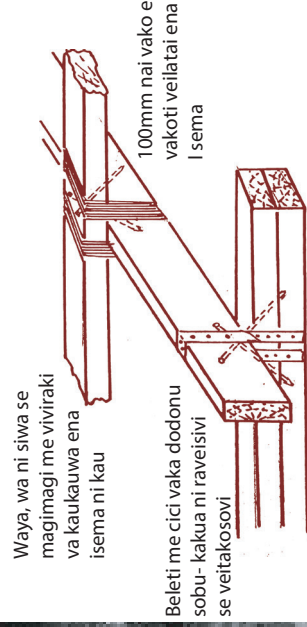

Me yava na ivako vaka uluna (40mm) e vakoti enai vesukadua ena dua na yasana

Vaka yagataka na kau kaukauwa se isogo kaukamea me ra maroroi kina na katuba leka

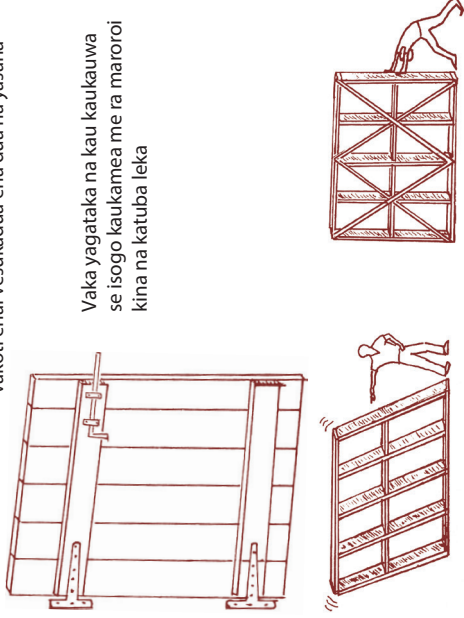

Na lalaga keina doka ka sega nai vaka dre veilatai e rawarawa saran a kenacaqera kira

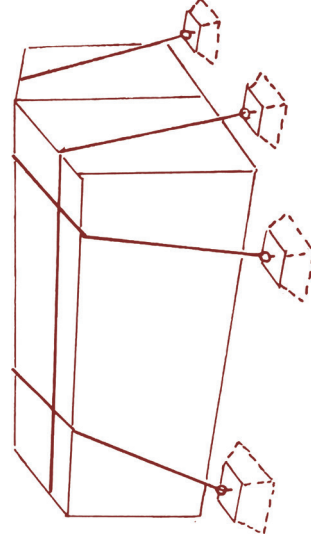

Vakai yagataka nai vakadre kappa me vesuka na doka.

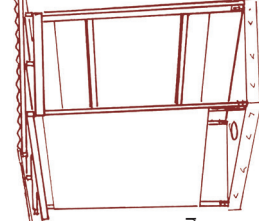

Yavutaka vaka vinaka na nomu valelailai ena loma ni qele



Shelter Cluster Fiji
 ShelterCluster.org
 Coordinating Humanitarian Shelter



Australian Aid



International Federation of Red Cross and Red Crescent Societies



Shelter Cluster Fiji
 ShelterCluster.org
 Coordinating Humanitarian Shelter

NI SA SEGA NI RAUTA GA NA IVAKO

Na veiyaya kece me tara kina na vale me ra dau vei semati vinaka va kaukauwa ka dabe vinaka na vale kina kena yavu.

Ni sa liwava na vale e dua na cagilaba nai vako esa sega ni kaukauwa vinaka me taura vata na vale. E na vanua era semati kina na kau ena yaga me vakayacori talega kina na veika oqo:

- Na ivako balavu e vakaukauwa taka na isema kevaka moici ka vako veilatai
- Na sukuru e kaukauwa cake mai na ivako
- Kei na isema kaukamea e kaukauwa cake mai na sukuru
- Na isema e qiva ka semati ena isema kaukamea e kaukauwa duadua

Na veisema taucoko ka tukuni tiko e cake era vakaukauwa taki cake ke vakayagataki talega na beleti, waya, waniwa se kau leleka.

Waya, wa ni siwa se magimagim e vesu wavoki va kaukauwa wavokita nai sema

Isema kapa e cici vaka dodonu sobu sega ni veisivi se vei kosovi

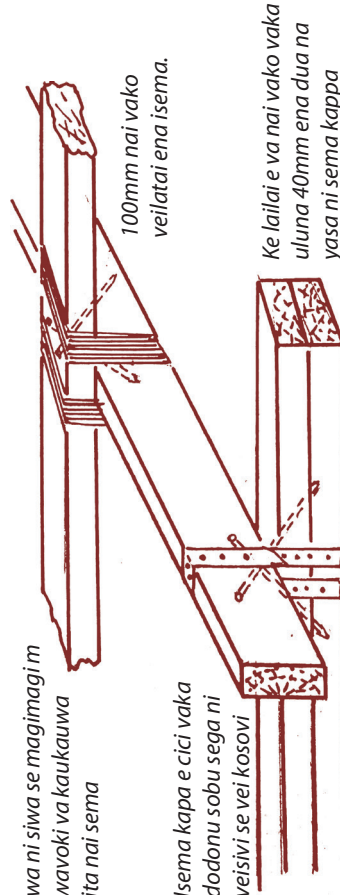

100mm nai vako veilatai ena isema.

Ke lailai e va nai vako vaka uluna 40mm ena dua na yasa ni sema kappa

E na rua se sivia nai sema ni kau, ena rawa ni kaukauwa na isema oqo ena isema kaukamea se peleti kau raraba ka qai sukuru se vako vata kena isema.

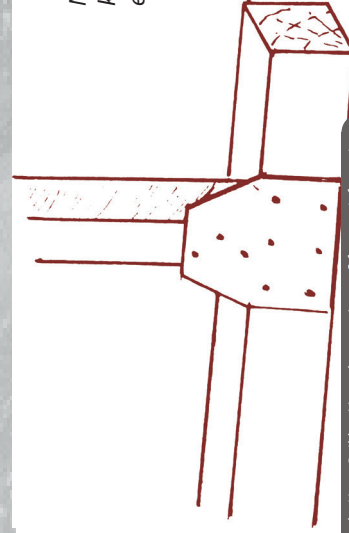

Na isema kaukamea se isema peleti kau raraba e kaukauwa ni vako se sukuru kina isema cakava ena yasana ruarua ke rawa

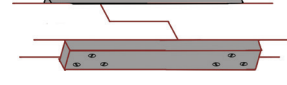

refer to the Home Builders Manual www.mit.gov.fj for more information

Na veika me caka e na kena tara vou
tale vakavinaka e dua na vale



Shelter Cluster Fiji
ShelterCluster.org
Coordinating Humanitarian Shelter



Shelter Cluster Fiji
ShelterCluster.org
Coordinating Humanitarian Shelter



International Federation
of Red Cross and Red Crescent Societies



Australian
Aid



Na veika me caka e na kena tara vou
tale vakavinaka e dua na vale



Shelter Cluster Fiji
ShelterCluster.org
Coordinating Humanitarian Shelter

AI VAKASALA NI TARA VALE ME MAROROI VINAKA NA NOMU VALE ENA GAUNA OQO, KEI NA GAUNA NI VEILEQA TUBU KOSO ESO

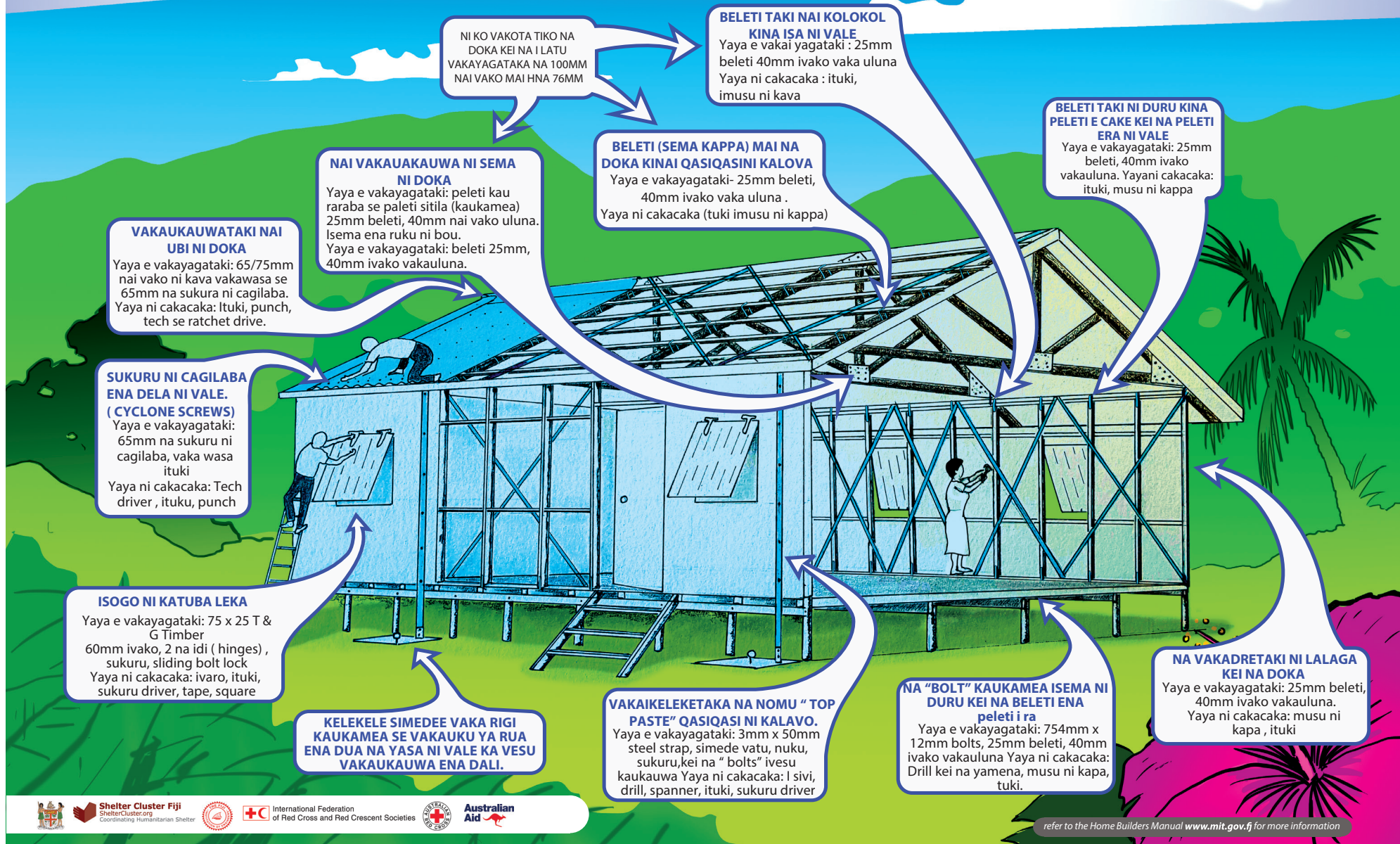

NI KO VAKOTA TIKO NA DOKA KEI NA I LATU VAKAYAGATAKA NA 100MM NAI VAKO MAI HNA 76MM

BELETI TAKI NAI KOLOKOL KINA ISA NI VALE
Yaya e vakai yagataki : 25mm beleti 40mm ivako vaka uluna
Yaya ni cakacaka : ituki, imusu ni kava

BELETI TAKI NI DURU KINA PELETI E CAKE KEI NA PELETI ERA NI VALE
Yaya e vakayagataki: 25mm beleti, 40mm ivako vakauluna. Yayani cakacaka: ituki, musu ni kappa

BELETI (SEMA KAPPA) MAI NA DOKA KINAI QASIQASINI KALOVO
Yaya e vakayagataki- 25mm beleti, 40mm ivako vaka uluna .
Yaya ni cakacaka (tuki imusu ni kappa)

NAI VAKAUAKAUWA NI SEMA NI DOKA
Yaya e vakayagataki: peleti kau raraba se paleti sitila (kaukamea) 25mm beleti, 40mm nai vako uluna. Isema ena ruku ni bou.
Yaya e vakayagataki: beleti 25mm, 40mm ivako vakauluna.

VAKAUKAUWATAKI NAI UBI NI DOKA
Yaya e vakayagataki: 65/75mm nai vako ni kava vakawasa se 65mm na sukuru ni cagilaba. Yaya ni cakacaka: Ituki, punch, tech se ratchet drive.

SUKURU NI CAGILABA ENA DELA NI VALE. (CYCLONE SCREWS)
Yaya e vakayagataki: 65mm na sukuru ni cagilaba, vaka wasa ituki
Yaya ni cakacaka: Tech driver , ituku, punch

ISOGO NI KATUBA LEKA
Yaya e vakayagataki: 75 x 25 T & G Timber
60mm ivako, 2 na idi (hinges) , sukuru, sliding bolt lock
Yaya ni cakacaka: ivaro, ituki, sukuru driver, tape, square

KELEKELE SIMEDEE VAKA RIGI KAUKAMEA SE VAKAUKU YA RUA ENA DUA NA YASA NI VALE KA VESU VAKAUKAUWA ENA DALI.

VAKAIKELEKETAKA NA NOMU " TOP PASTE" QASIQASI NI KALAVO.
Yaya e vakayagataki: 3mm x 50mm steel strap, simede vatu, nuku, sukuru, kei na " bolts" ivesu kaukauwa
Yaya ni cakacaka: I sivi, drill, spanner, ituki, sukuru driver

NA "BOLT" KAUKAMEA ISEMA NI DURU KEI NA BELETI ENA PELETI I RA
Yaya e vakayagataki: 754mm x 12mm bolts, 25mm beleti, 40mm ivako vakauluna
Yaya ni cakacaka: Drill kei na yamena, musu ni kapa, tuki.

NA VAKADRETAKI NI LALAGA KEI NA DOKA
Yaya e vakayagataki: 25mm beleti, 40mm ivako vakauluna.
Yaya ni cakacaka: musu ni kapa , ituki



refer to the Home Builders Manual www.mit.gov.fj for more information



Na veika me caka e na kena tara vou tale vakavinaka e dua na vale



Shelter Cluster Fiji
ShelterCluster.org
Coordinating Humanitarian Shelter



Na vale ivakrurur ka tara ni oti na cagilaba ni oti ko TC. Winston (Tabana ni kauvaelatai Damudamu / IFRC)



Taba ni veivakacokotaki kina. Lewe ni vanua e viti era tara vale tiko kara vaka vulici tale tikoga kina tara na vale kaukauwa ka veimarorori vinaka (contact hfhfiji@habitatfiji.org.fj.ph:3312012)

30

Ai tukutuku ni tara lesu tale vakavinaka

- ✓ Shelter cluster Fiji: Na taba ni vei vakacokotakie viti e sasagataka vakabibib me solia lesu kivei ira ka laka leqai na nodra I tikotiko ena leqa tubu koso na vale e kaukauwa ka uasivi ka mororoi vinaka kina na bula. Na matanitu e liutaka na tabana oqo ena Ministri ni Matanitu vakaitikotiko, veivakavaletaki kei na veika e vakavolivoliti keda. E lesu sara nai vola tukutuku kei nai vola dusidusi e tiko ena Shelter Cluster Fiji Website.
<http://sheltercluster.org/library/fiji-building-back-safer-technical-library>
- ✓ The National Building Code of Fiji Na lawa ni tara vale ni matanitu ko Viti e dua nai vola ni tukutuku ni cakacaka ka rad au vakamuraia na dau ni tara vale lelevu ena kabani ka ra cici vakataki ira ena veikoro lelevu. E vakadeitaki na kena dau vakayagataki na lawatu oqo ena kena vakadewataki me baleta na lawa tawani ena veivakalawataki. Nai vola ni tara vale tawani (Home Builders Manual) e vakadewataki na lawa gadrevi kina tara vale oqo. Nai vola oqo e vakarautaka na kena tara na vale duadua, taba rua, ka vakamacalataka talega nai taratara kei nai dadedabe ni vale; ka sa vakamacalataka tu oqo ena " Tara Lesu Vakavina-ka me matata kivua nai tau kei ni vale, kei ira na dau tara vale.
<http://www.mit.gov.fj/images/2016/home%20building%20manual%20fiji.pdf>
- ✓ Na veitukutuku vata vakakoya e rawa ni lau rai ena Pacific Disability Forum ena pdfsec@unwired.com.fj kei <http://www.pacificdisability.org/>
- ✓ Na international Federation Of Red Cross and Red Crescent Societies (IFRC) Tabana ni kauveilatai damudamu e sa cakava e dua nai vola tukutuku "Shelter Safety Handbook" ka vakaikuritaki ena I tukutuku mai na Tara Lesu vakavinaka. Building Back Safer
<http://www.ifrc.org/PageFiles/95526/publications/305400Shelter%20safety%20handbook-EN-LR.pdf>
- ✓ CBM Handicap International kei na IFRC e tabaka na "All Under One Roof :Tau-coko ena ruku ni dua ga na doka" Wilikina nai tikotiko ni vakaleqai ni tikotiko ni yago kei na , vakasala ni veivuke gadrevi vakatotolo.
<http://www.ifrc.org/Global/Documents/Secretariat/Shelter/All-under-one-roof-EN.pdf>

31





© Shelter Cluster Fiji, 2016. Oqo e dua nai vola vakarautaki, ka rawa ni vakayagataki na kena veigacagaca kina veiqaravi tale eso, ia me qai nanumi tu ko ira era a vakarautaka

Na kena vakamuri vakavinaka na i walewale ni tara vale e na i vola vakarautaki oqo, e sa na vakatautaki sara ga vei keda ya dua, se kabani, se i soqosoqo.

Na “Help for Homes” Veivuke ena veivakavaletaki kei na I Tukutuku ni Tara Lesu Vakavinaka tips to build back safer, e vola tabaki mai na Shelter Cluster Fiji me vukei ira na lewei viti me ra tara na vale e vinaka cake ni oti na cagilaba rerevaki ko TC. Winston. Vakavinavinaka kina nodra veivuke levu na veitabana oqo;



 International Federation of Red Cross and Red Crescent Societies



the power of humanity



 The Netherlands Red Cross





Matai ni lavelave, **Shelter Cluster Fiji, September 2016**

